

METRIC NYLON LOCK NUT SIZE CHART

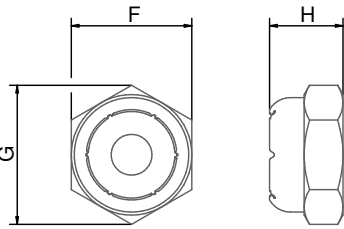

F - Width Across the Flats
G - Width Across Corners
H - Thickness



Nut Sizes		M2.5	M3	M4
Thread Pitch - Course [mm]	0.45	0.50	0.70	0.80
Thread Pitch - Fine [mm]	0.35	0.35	0.50	0.50
Width Across the Flats [mm]	5.0	5.5	7.0	8.0
Width Across Corners [mm]	5.77	6.35	8.08	9.24
Thickness [mm]	3.38	4.0	5.0	5.0

"Width Across the Flats" is the same as "Wrench Size"

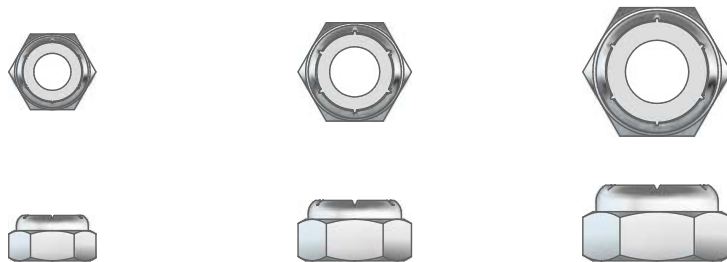

Nut Sizes	M6	M8	M10
Thread Pitch - Course [mm]	1.00	1.25	1.50
Thread Pitch - Fine [mm]	0.75	1.00	1.25
	-	0.75	1.00
	-	-	0.75
Width Across the Flats [mm]	10.0	13.0	17.0
Width Across Corners [mm]	11.55	15.01	19.63
Thickness [mm]	6.0	8.0	10.0

"Width Across the Flats" is the same as "Wrench Size"



METRIC NYLON LOCK NUT SIZE CHART

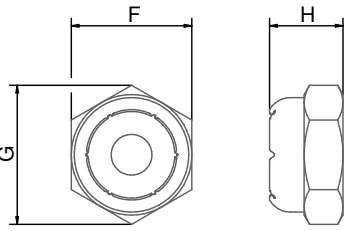

F - Width Across the Flats
 G - Width Across Corners
 H - Thickness

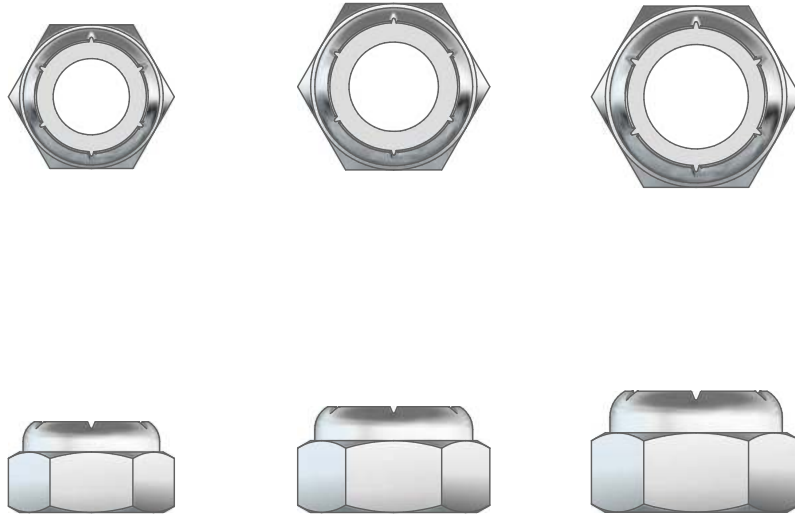

Nut Sizes	M12	M14	M16
Thread Pitch - Course [mm]	1.75	2.00	2.00
Thread Pitch - Fine [mm]	1.50	1.50	1.50
	1.25	1.25	1.00
	1.00	1.00	-
Width Across the Flats [mm]	19.0	22.0	24.0
Width Across Corners [mm]	21.94	25.40	27.71
Thickness [mm]	12.0	14.0	16.0

"Width Across the Flats" is the same as "Wrench Size"



METRIC NYLON LOCK NUT SIZE CHART

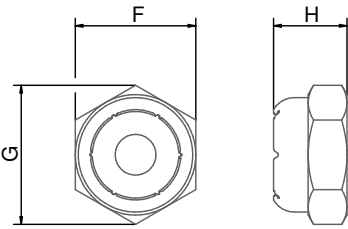

F - Width Across the Flats
 G - Width Across Corners
 H - Thickness

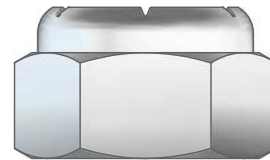
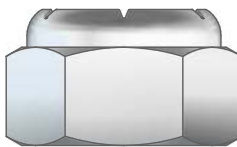

Nut Sizes	M18	M20
Thread Pitch - Course [mm]	2.50	2.50
Thread Pitch - Fine [mm]	2.00	2.00
	1.50	1.50
	1.00	1.00
Width Across the Flats [mm]	27.0	30.0
Width Across Corners [mm]	31.18	34.64
Thickness [mm]	18.5	20.0

"Width Across the Flats" is the same as "Wrench Size"

