

SHORT ARM ALLEN KEYS

METRIC

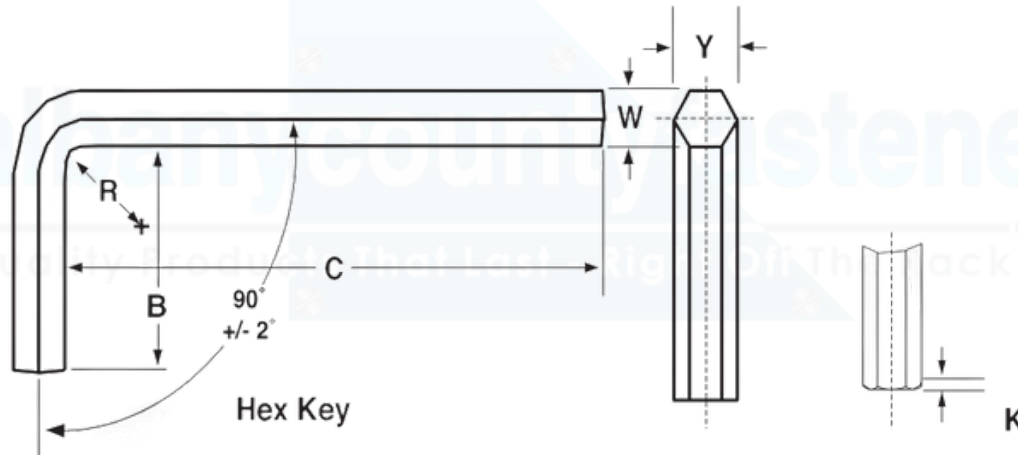

METRIC Hex Keys, Long and Short Arm

Nominal Key and socket Size	W		Y		B		C		R	K	Torsional Strength (N/m)
	Hex Width Across the Flats		Hex Width Across the Corners		Length of Short Section		Length of Long Section		Radius of Bend	Chamfer	
	Max	Min	Max	Min	Max	Min	Max	Min			
M1.5	1.500	1.470	1.690	1.640	14	13	45	1.125	1.5	0.14	1.0
M2	2.000	1.970	2.250	2.200	16	15	50	1.125	2.0	0.14	2.1
M2.5	2.500	2.470	2.820	2.770	18	17	56	1.562	2.5	0.14	4.7
M3	3.000	2.960	3.399	3.340	20	18	63	1.656	3.0	0.18	7.7
M4	4.000	3.960	4.532	4.470	25	23	70	1.781	4.0	0.24	17.8
M5	5.000	4.960	5.690	5.630	28	26	80	1.906	5.0	0.30	35.0
M6	6.000	5.950	6.828	6.760	32	30	90	2.031	6.0	0.36	57.0
M8	8.000	7.950	9.136	9.030	36	34	100	2.156	8.0	0.49	126.0
M10	10.000	9.950	11.470	11.340	40	38	112	2.281	10.0	0.62	252.0
M12	12.000	11.950	13.764	13.590	45	43	125	2.406	12.0	0.76	420.0
M14	14.000	13.930	16.058	15.880	56	53			14.0	0.85	670.0
M17	17.000	16.930	19.499	19.300	63	60			17.0	1.04	1180.0
M19	19.000	18.930	21.793	21.580	70	67			19.0	1.16	1670.0